

SCOT FORGE



Money Saving Tips: Forged Hub Solutions

Box 8, 8001 Winn Road • Spring Grove, IL 60081

PROBLEM

When hub shapes are achieved through machining solid bar stock or flame cutting plate, waste is an inescapable part of the process.

- When machining a shape from solid bar or flame cutting plate, all excess material - material paid for - is lost. See the illustration to the right.
- Machining or flame-cutting means costly machine time, lowered tool life, and increased freight costs for material.
- Most importantly, the uni-directional grain flow of both bar and plate increases the likelihood of failure due to fatigue.

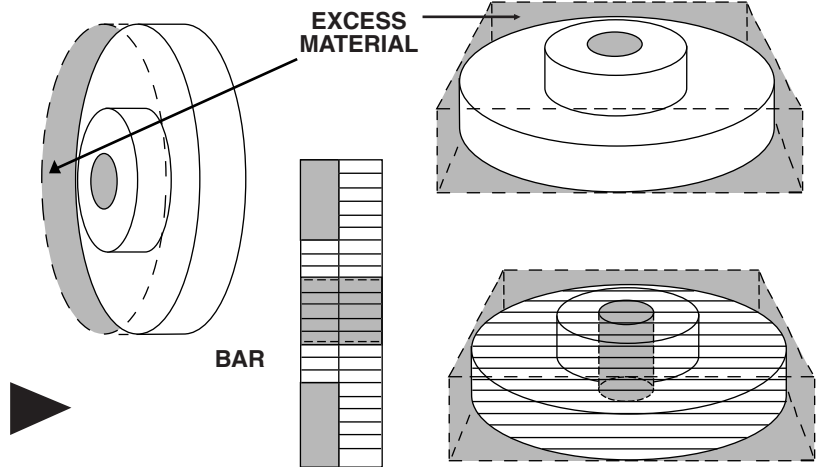

SOLUTION

Custom forging of hub shapes improves quality, lowers material costs - and offers maximum flexibility.

- As it requires less material from the start, forging saves on both material and freight costs.
- The forging process requires simple tooling yet can produce virtually limitless combinations of single or double hub sizes.
- Reduced machining saves time, labor, and tooling costs - and forging produces a nearer net shape!
- The optimum combination of strength, toughness, and fatigue resistance in the hub is achieved by the continuous grain flow which comes through forging.

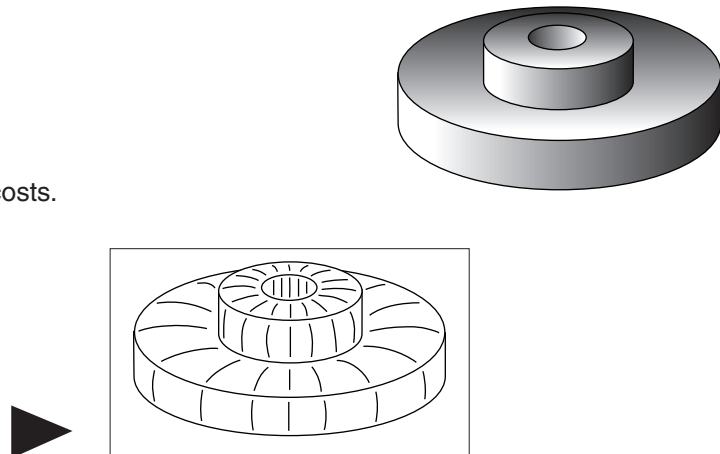

FORGING ALLOWS SIZE VARIETY AND MATERIAL SAVINGS

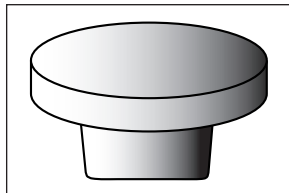

Forged Sizes
20" O.D. X 3" Face, Hub one side
9" O.D. X 4 1/2" Projection
Weight = 348 lbs.

Plate Size
20" Square X 7 1/2" Thick
Weight = 850 lbs.

**59%
MATERIAL
SAVINGS**

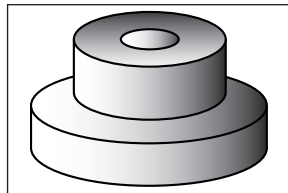

Forged Sizes
18 1/2" O.D. X 3 3/8" Face,
Hub one side
10 5/8" O.D. X 6 1/8" Projection
with a 3" I.D. through
Weight = 421 lbs.

Bar Size
18 1/2" O.D. X 10" Long
Weight = 741 lbs.

**43%
MATERIAL
SAVINGS**

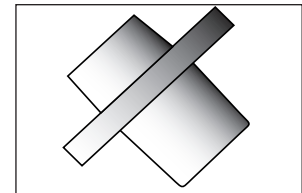

Forged Sizes
9" O.D. X 1 1/8" Face, Hub one side
4" O.D. X 1 3/4" Projection, Hub other side
4" O.D. X 3 1/2" Projection
Weight = 39 lbs.

Bar Size
9" O.D. X 6 5/8" Long
Weight = 115 lbs.

**66%
MATERIAL
SAVINGS**

Call us with the finished sizes of your hubs and realize tremendous savings by ordering from Scot Forge.
847/587-1000 • 800/435-6621 • Fax: 847/587-2000 • sales@scotforge.com • www.scotforge.com

ISO 9002 Certified!